

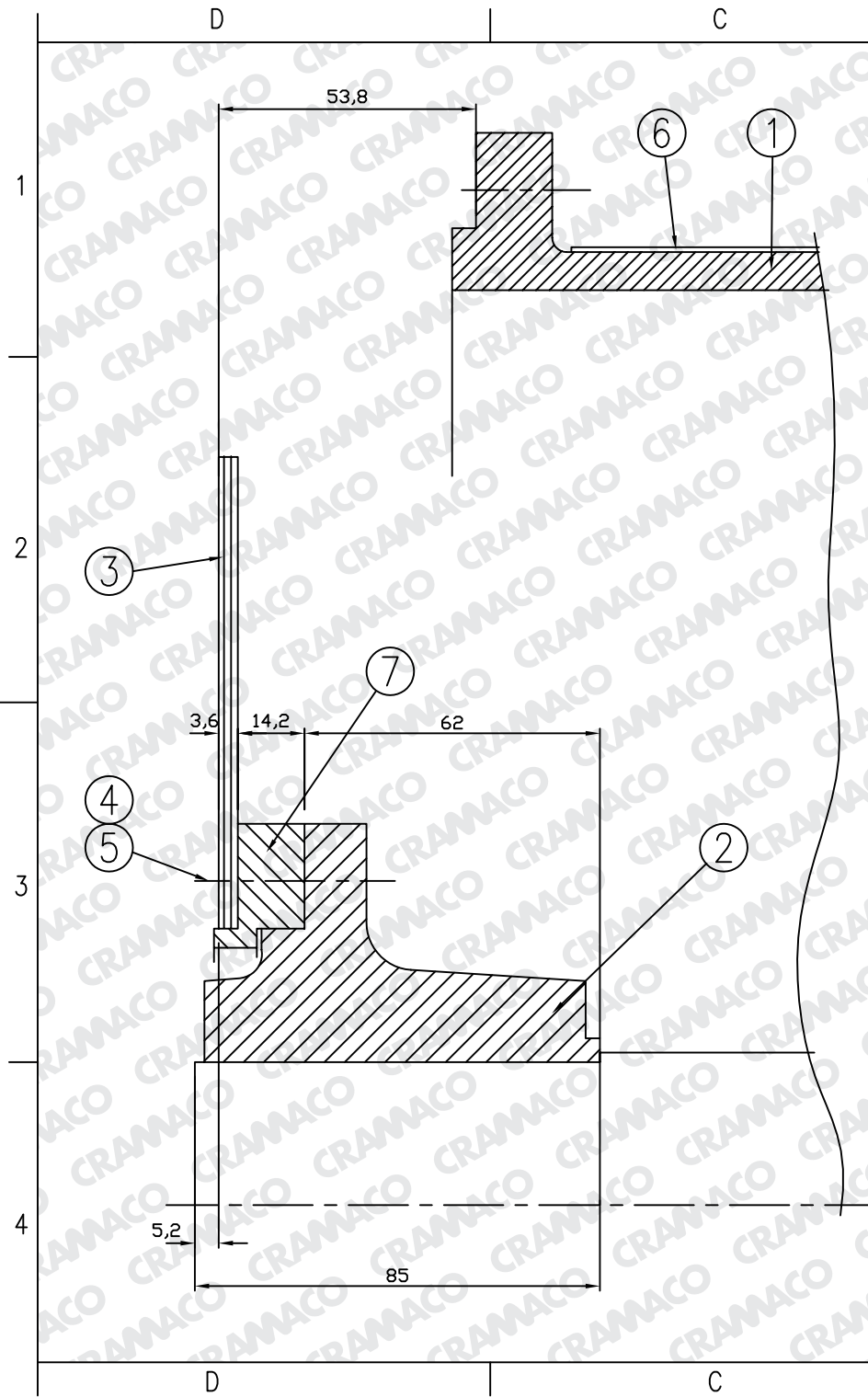

O.T.N	LETRA	ALTERACION.	CORREGIDO
5209	A	MODIFICADO COTA 62 ERA 60,8	CELSO 1/4/04

CRAMACO



7	ARO INTERMEDIO	1		19438/1
6	REJILLA DE PROTECCION	1		18339
5	ARANDELA DE MUELLE B10-DIN 127	10	SAE 1070	
4	TORNILLO EXAGONAL M10x40-DIN 933	10	CALIDAD 10.9-GAL.	
3	DISCO DE ACOPLE	3		18077
2	CUBO DE ACOPLE	1		18476
1	TAPA	1		18238

ORDEN	DENOMINACION	PESO k.g	CANT.	MATERIAL	PLANO
ESTE PLANO ES PROPIEDAD DE DBT S.A. Prohibida su copia o reproducción sin el consentimiento expreso de la firma.		DIMENSIONES EN: m.m ESCALA: 1:1 BASADO EN: NO MEDIR SOBRE EL DIBUJO		 DBT S.A. CRAMACO® Dpto. Técnico	
DIB.	CELSO	16/4/03	ACOPLAMIENTO SAE 3 / SAE 10 G2R 200		
REV.			PLANO N° 19437		BARRA A
APR.					