

CONFIDENTIAL INFORMATION
 OF BASLER ELECTRIC COMPANY, HIGHLAND, IL.
 IT IS LOANED FOR CONFIDENTIAL USE, SUBJECT
 TO RETURN ON REQUEST, AND WITH THE
 MUTUAL UNDERSTANDING THAT IT WILL NOT BE
 USED IN ANY MANNER DETRIMENTAL TO THE
 INTEREST OF BASLER ELECTRIC COMPANY.

**INSTRUCTION MANUAL
 FOR
 VOLTAGE REGULATOR
 Model: VR63-4/UL**

Publication:
 9 1668 00 994
 © 1998, Basler Electric Co., Highland, IL 62249
 First Printing March 1984
 Revision: J
 ECO: 143
 September 1998

BASLER ELECTRIC, BOX 269, HIGHLAND, IL 62249 PHONE 618/654-2341 FAX 618/654-2351

INTRODUCTION

The VR63-4/UL Voltage Regulators are designed for use on 50/60 Hz brushless generators. The regulator includes frequency compensation, overexcitation shutdown, a solid-state build-up circuit, and EMI filtering.

WARNING
 To prevent personal injury or equipment damage, only qualified technicians or operators should install, operate, or service this device.

ELECTRICAL SPECIFICATIONS

Dc Output Power:

4 Adc at 63 Vdc (252W) maximum continuous,
 7 Adc at 100 Vdc (700W) forcing one minute (at 240 Vac input).

Exciter Field Dc Resistance:

15 ohms minimum; 100 ohms maximum.

Ac Power Input:

Operating range: 190 Vac to 240 Vac, $\pm 10\%$
 Single phase, 50/60 Hz, Burden 500 VA.

Sensing Input:

190-240 Vac, Single phase, 50/60 Hz $\pm 10\%$, common with AC Power Input.

Voltage Adjust Range:

171-264 Vac.

Regulation Accuracy:

Better than $\pm 1.0\%$ no load to full load.

Response Time:

Less than 1.5 cycles for $\pm 10\%$ change in sensing voltage.

EMI Suppression:

Internal electromagnetic interference filter (EMI filter).

Overexcitation Shutdown:

Output power is removed under the following conditions: Exciter field voltage exceeds 100 ± 5 Vdc for a time inversely proportional to voltage magnitude, or instantaneously if the exciter field voltage exceeds 135 ± 5 Vdc.

Voltage Build-up:

Internal provisions for automatic voltage build-up from generator residual voltages as low as 10 Vac.

Power Dissipation:

8 Watts maximum.

PHYSICAL SPECIFICATIONS

Operating Temperature:

-40° C (-40° F) to $+60^{\circ}$ C ($+140^{\circ}$ F).

Storage Temperature:

-65° C (-85° F) to $+85^{\circ}$ C ($+185^{\circ}$ F).

Vibration:

Withstands 1.3 Gs at 2 to 27 Hz; 0.036" double amplitude at 27 to 52 Hz; and 5 Gs at 52 to 1000 Hz.

Shock:

Withstands up to 20 Gs in each of three mutually perpendicular axes.

Weight:

14 oz. (0.40 kg) Net.

CSA Approved/UL Recognized

FUSES

It is recommended that fuses with high interruption capability be installed per the interconnection diagram to protect wiring from faults before the regulator. Refer to the *Interconnection Drawings*.

NOTE
 Fuse must be installed per the interconnection diagrams to avoid interrupting the field current.

MOUNTING

The regulator may be mounted in any position. Refer to the drilling diagrams.

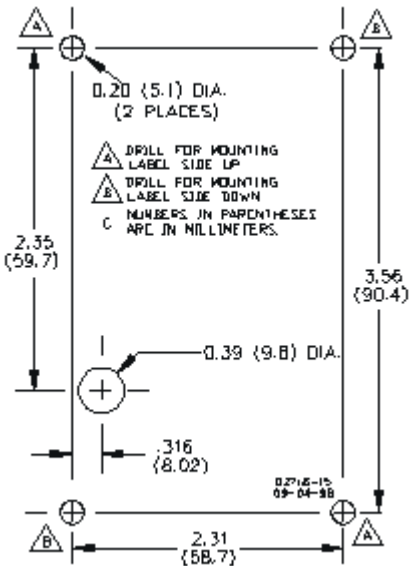

Drilling Diagram

EXCITER FIELD POWER CIRCUIT (wires F+ and F-).

Connect the regulator wire F+ to the brushless exciter field terminal F+, and wire F- to terminal F-.

CAUTION
 The dc resistance of the exciter field must be equal to or greater than 15 ohms and less than 100 ohms.

POWER/SENSING INPUT CIRCUIT (wires 3 and 4)

Connect as shown by the *Interconnection Diagrams*.

Power for the exciter field and regulator circuitry is derived from the generator output or auxiliary winding. The operable power input range is 171 to 264 Vac and is connected to Terminals 3 and 4.

FREQUENCY COMPENSATION

The frequency compensation characteristic is to improve system load pickup performance by restraining voltage recovery until frequency has also started to recover.

For 50 Hz system, the regulator is preset at the factory for a 45 Hz "corner frequency". For 60 Hz systems, a 55 Hz "corner frequency" is achieved by cutting the external Hz jumper wires on the generator. Be sure to insulate the the two wires so that they are not exposed.

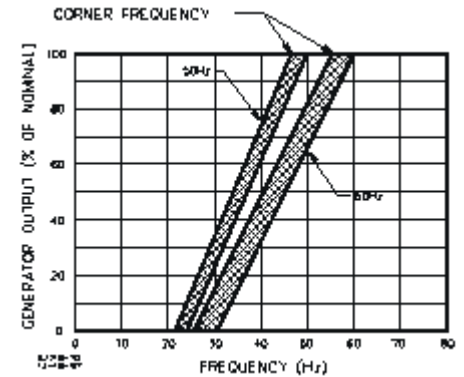

Frequency Compensation Curves

OVEREXCITATION SHUTDOWN

If the exciter field voltage exceeds 100 ± 5 Vdc, the regulator automatically removes the field current after a time delay. The time delay is inversely proportional to the magnitude of the detected overvoltage condition up to the 135 Vdc point. Beyond 140 Vdc, the field voltage is removed within 0.2 seconds.

After shutdown, reset the regulator by decreasing voltage below 6 Vac either by stopping the prime mover or interrupting the regulator input with a reset switch for 2 seconds or more.

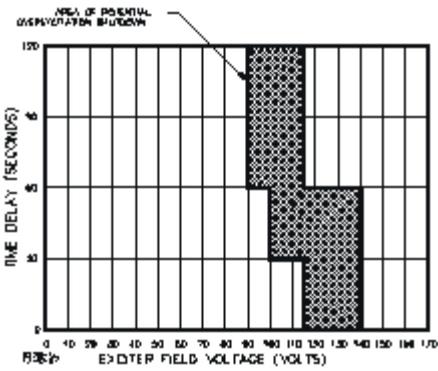

Typical Time Delay Characteristic Curves

VOLTAGE ADJUST RHEOSTAT

Screwdriver adjustable potentiometer adjusts generator output voltage. Adjustment CW increases voltage.

When using remote voltage adjust rheostat (VAR), the VAR wire on the regulator should be cut and the rheostat connected to both ends. A 1 kohm and 1/2 watt resistance is adequate for most applications. See *Interconnection Diagrams*.

OPERATION

The following system operation procedures provide instructions for adjusting the VR63-4/UL Voltage Regulator.

CAUTION

Meggars and high potential test equipment must not be used. Incorrect use of such equipment could damage the

semiconductors contained in the regulator.

PRELIMINARY SET-UP

To prevent damage to the regulator, complete the following steps before proceeding with system start-up.

- Verify that the voltage regulator specification conforms with the generator system requirements.
- Ensure that the regulator is correctly connected to the generator. See *Interconnection Diagram*.
- Install fuses per *FUSES* paragraph.
- Set the regulator VAR fully CCW and the remoteVAR (if used) to centered.

SYSTEM START-UP

- Start the prime mover and bring up to rated speed. Voltage should buildup. If a minimum residual of 6 Vac is not present, perform field flashing.
- Slowly adjust VAR CW until voltage reaches nominal value. If used, adjust remote voltage adjust to set generator output to exact value desired.

OPERATIONAL TEST

- Connect the test setup as shown in *Operational Test*. Do not apply power. Ensure that light bulbs are rated for 120 V and less than 100 W.
- Adjust regulator VAR and/or remote VAR to maximum CCW.
- Apply 240V, 60 Hz power to regulator.

- Slowly adjust the regulator VAR control CW.

RESULT:

- Before minimum brilliance is reached, the light bulb should attain maximum brilliance to signify the regulating point.
- At the regulating point, a small change in the VAR should turn the light bulb on or off.

FIELD FLASHING

When the regulator is operated with the generator for the first time, the polarity of residual magnetism may not correct or the magnitude not enough. If the generator does not build-up after startup, shut down the prime mover and proceed with the following steps:

- With the prime mover at rest, apply a dc source (not grounded) of not more than 12V, to terminals F+(positive) and F-(negative) in series with a limiting resistor of 3-5 ohms.
- Allow approximately 3 seconds before removing the dc source.
- Start prime mover and measure voltage at regulator leads 3 and 4. If voltage is greater than 6 volts, voltage build-up should be successful. Repeat field flashing procedure if less than 6 V residual is measured.
- If repeating steps 1 and 2 does not result in generator voltage build-up, replace the voltage regulator.

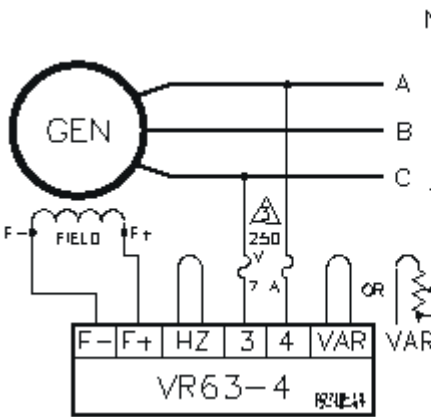

- NOTES:
- CUT HZ LEADS FOR 60 HZ OPERATION
 - FOR REMOTE VAR. 10% 1000 OHMS 5% 500 OHMS +/- 10% 1/2 W POT.
 - FAST-BLOW, HIGH INTERRUPT CAPABILITY.

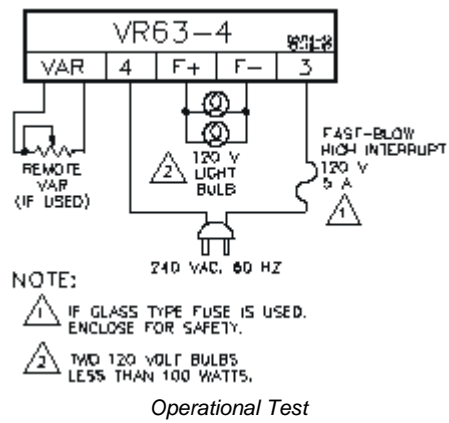

Interconnection Diagram, 208-240 V Nominal